

Over Idle Protection System

IdleCheck

A dual function system that provides standard idle timer operation with the added benefit of an Over-Idle protection system that will automatically shut the machine down during extended idling periods

BENEFITS

- Engine & turbo component life extended
- Automatic shutdown reduces operator waiting time
- Prevents glazing of cylinder bore due to over idling
- Reduces Fuel Consumption

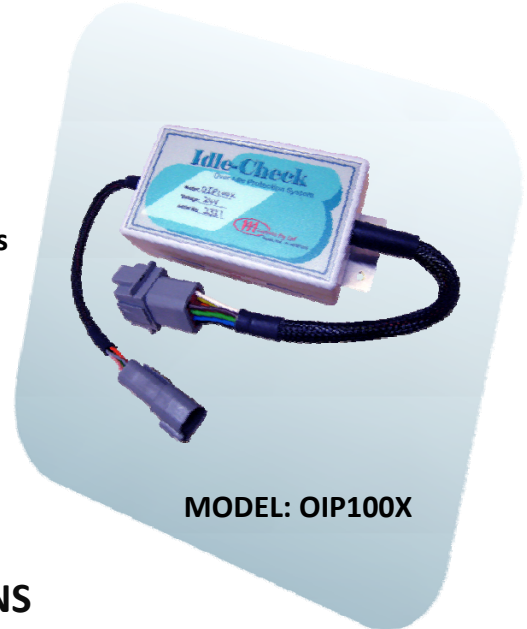

MODEL: OIP100X

FEATURES

- Dual Function System
- User Selectable Timing
- Compact Design
- Simple Installation
- Australian Design & Manufacture
- Low Profile Combination Indicator / Override Switch

SPECIFICATIONS

Voltage	24V
Standby Current	10mA
Operating Current	85mA
Timing Accuracy	0.1%
Maximum Load	5 Amp Single Output – 10 Amp Dual Output
Setup	DIP Switches
Engine Speed	20Hz-15KHz (1V minimum P/P)

Typical Installation Schematic

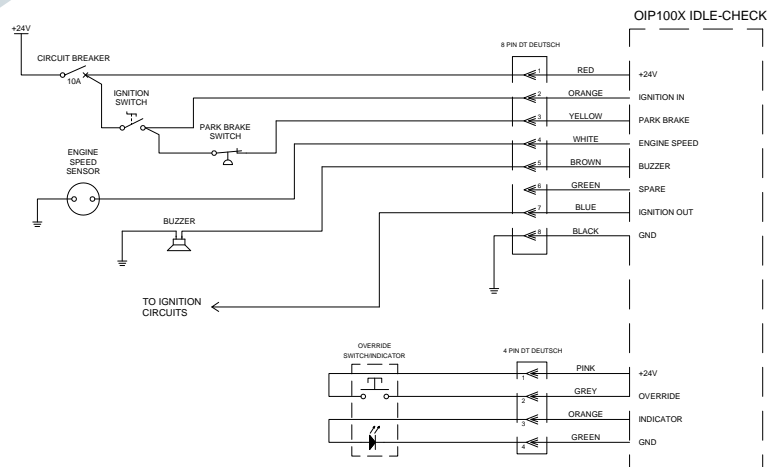

sales@montronics.com.au

SYDNEY
67 Silverdale Rd
Silverdale NSW 2752
Ph: (02) 4774 1228
Fax: (02) 4774 1136

HUNTER VALLEY
Unit 3, Lot 1 Rosella St
Singleton NSW 2330
Ph: (02) 6571 2775
Fax: (02) 6571 2776